



KÖNIGHAUS

INFRAROT

Original instruction manual
Far-infrared heating



Original instruction manual

Far-infrared heating

Model: Könighaus- E-, M-, P-, G, GS-series, mirror, arc, hybrid

**Important: This product is only suitable for well insulated rooms
or for occasional use suitable for use.**

Read carefully before use
Keep for reference

Ownership

This manual is a property of:
Könighaus GmbH
Albert-Einstein-Straße 1
D-46446 Emmerich am Rhein

Version V1.11

© 2023

The distribution and duplication of these documents, exploitation and communication of their contents are not allowed, unless expressly permitted. Violations oblige to compensation. All rights reserved in the event of patent grant or utility model registration.

Change index

Date	Version	Chapter	Reason	Responsibility
9.10.2015	V 0.0	All	Updating	uttc Ingenieurgesellschaft GmbH Friedrich-Heinrich-Allee 159 D-47475 Kamp-Lintfort E-Mail: info@uttc.de Auftrag 2015-1668
03.12.2015	V 1.0	All	G- und GS-Serie hinzugefügt	
03.08.2016	V 1.1	General information, Chapter 4.5 Chapter 8	Address changed, Added IP protection class, Declaration of Conformity updated	
06.09.2016	V 1.2	All	Modifications in accordance with the amended requirements with regard to the Sales Suitability Certificate	
		Chapter 1.2.1	Modification in the assembly of the ceiling	
31.08.2017	V 1.3	All	Modifications of series E	
22.01.2018	V 1.4	All	Amendments in conformity with Regulation (EU) 2015/1188	
28.01.2019	V 1.5	All	Added additional devices	
19.02.2019	V 1.6	Chapter 6	On/off switch specified	
23.04.2019	V 1.7	All	Device updates, new P series	
20.09.2019	V 1.8	All	Text changes	
24.04.2020	V 1.9	All	Logo and product update	
23.10.2020	V 1.10	All	Hybrid-series	
05.01.2021	V 1.11	All	Changes Notes of the white panels	

These operating instructions have been prepared by us to the best of our knowledge. Should you nevertheless discover any errors or ambiguities, please let us know. Furthermore, we would appreciate any hints and suggestions.

Please contact us:

Könighaus GmbH
Albert-Einstein-Straße 1
D-46446 Emmerich am Rhein
Tel.: +49 2822/5376401

E-Mail: info@koenighaus-infrarot.de
Internet: www.koenighaus-infrarot.de

Content

1	Product information	6
1.1	Before using an infrared heater	6
1.2	Far Infrared Heaters	6
1.3	Various mounting types	8
1.3.1	Ceiling mount	8
1.3.2	Wall mount	8
1.3.3	Mobile operation with aluminium and wood feet	8
1.3.4	Direct installation on the power circuit	8
2	Reading references	9
2.1	Abbreviations, synonyms, symbols	9
2.2	Safety-related information	9
3	Legal Regulations	11
3.1	Disclaimers	12
3.2	Applicable guidelines	12
3.3	Sales within non-European economic areas	12
4	Safety	13
4.1	Intended use	13
4.2	Technical data	14
4.2.1	Notes on energy consumption	15
4.3	Nameplate	17
4.3.1	Labelling on the machine	17
4.4	Safety Instructions	18
5	Mounting	21
5.1	General notes on mounting	21
5.1.1	Installation of the Könighaus E-series	23
5.1.2	Installation of Könighaus P-, DL-series, GSP 800 and GSP-1000	24
5.1.3	Installation der Könighaus M-, G-, GS- and SP series	25
5.2	Positioning	26
5.2.1	Mounting and stand	27
6	Commissioning	28
6.1	Notice on handling	28
7	Cleaning and maintenance	29
7.1	Cleaning	29
7.2	Repair	29
8	Troubleshooting	30
9	Declaration of Conformity	32
10	Guarantee provision statement	34

1 Product information

Foreword

Thank you for choosing a far infrared heating system from Königshaus Heizsysteme.

Far infrared heaters are electric heaters and work with electricity. As a result, there is a certain risk potential. It is therefore important to read these operating instructions carefully before starting up the heater. Furthermore, the operating instructions should always be kept close to the device.

If you have any doubts or questions, please do not hesitate to contact us.

1.1 Before using your infrared heater



- Before using your infrared heater, please read the safety instructions and the operating instructions carefully. This is the only way to use all functions safely and reliably.
- Please ensure that there is sufficient ventilation during the first start-up (approx. four hours).
- Under no circumstances should the unit be covered during operation. Direct contact can lead to heat accumulation and thus cause a fire hazard. The minimum distance of 50 cm must not be exceeded.

1.2 Far Infrared Heaters

Far infrared heaters are direct heaters that operate on the principle of heat radiation (infrared). They do not need much energy to create a comfortable and pleasant room climate.

Due to an energy conversion of almost 100 %, the far infrared heaters are very efficient in transmission. The surfaces of the heating panels are designed to achieve optimum heat dissipation at wavelengths ranging from 6 to 15 µm.

The heating panels use the same principle of solar heating, whereby the heat waves irradiate bodies and objects, which in turn emit the heat. The resulting

indoor climate corresponds to a climate generated by natural solar radiation. Furthermore, the formation of mould is prevented because the walls store the heat much longer and more effectively than with convection heating.

Far infrared heaters can be used for a wide variety of buildings or rooms and their environments. Depending on the environment and type of application, different models are recommended. Our consultants will be happy to assist you in the selection of the individual model. There are different installation instructions for different models. These should be strictly observed. (see below).

The infrared panels with remote control heat up to working temperature for only a few minutes (about 5 to 10 minutes). You will find more information in Chapter 2. If you do not feel a warm and comfortable temperature in the room immediately after a short time, continue operating the far infrared heater until the items and objects in the room are heated up. After the first introductory phase, the heater should use little energy to heat the room, as objects and walls are heated.

Depending on the model, the surface will heat up to 80 to 125 °C. All our far-infrared heaters are equipped with overheating protection, which automatically switches off the heating operation of the device in the event of overheating.

1.3 Various mounting types

1.3.1 Ceiling mount

With the M series, ceiling mounting is possible. For safety reasons, this should only be carried out by a specialist. Please note but urgently follow the instructions for mounting.

1.3.2 Wall mount

Far infrared heaters are the perfect auxiliary or main heating systems for residential areas. Due to the aesthetic aspect and the space-saving design of our far infrared heating systems, they can be installed in almost any environment. (Please observe the instructions for installation).

1.3.3 Mobile operation with aluminium and wood feet

Our far infrared heaters can be used very well with our aluminium or wood feet which are mobile and flexible at different places. For this reason, mount the feet on the outer frame. For stability reasons, we recommend mounting on the wide side of the heater and thus operation in horizontal format.

1.3.4 Direct installation on the power circuit

Our series M without a plug is designed for direct installation on the power supply circuit and may only be installed by a specialist. If this is not observed, warranty claims and liability claims will not be granted and a risk may arise.

Reading references

2

Abbreviations, synonyms, symbols

2.1

Abbreviation/Synonym	Significance
EMC	Electromagnetic compatibility
Device	Far infrared heating

Symbol	Significance
>>	Instructions for action
•	Bulleted list
Italic	Name of a key, a button, a switch

Safety-related information

2.2

Symbol  warns you of personal injury.

These operating instructions contain safety-related information:

- Chapter 4  safety, as warnings in individual chapters.
- The safety-related information explains the dangers on the machine and how you can avoid these dangers.

Read the safety-related information carefully. With your knowledge, you can recognize dangerous situations and protect yourself and others.

Chapter Security

This chapter  informs you about measures for your safety. The information is intended to raise your awareness of safe behaviour.

The aim is to provide a basis for training and instruction.

Warning instructions

Several chapters of this operating manual contain warnings. A warning always warns you of an imminent danger. It is to be understood in connection with the situation in which the warning is given.

The aim is to avoid accidents and damage.



Signal word

This warning text mentions the hazard. This warning text states the consequences.

>> This instruction names the remedy.

Signal word	Risk level of the hazard	Significance
DANGER	high	Death or serious injury will occur if the hazard is not avoided.
WARNING	medium	Death, serious injury may occur if the hazard is not avoided.
CAUTION	low	Minor or moderate injuries may occur if the hazard is not avoided.

Legal regulations

3

Disclaimers

3.1

No warranty is given for damages caused by the following reasons:

- Unauthorized or improper use of the device.
- Failure to observe the instructions in this operating manual regarding transport, storage, installation, commissioning, operation, maintenance, servicing or other measures on the device.
- Incorrect installation or commissioning.
- Unauthorized modifications and changes to the device.
- Natural wear and tear.
- Unsuitable operating materials and spare parts.
- Improperly performed repairs.
- Chemical, electrochemical or electrical influences.
- Disasters caused by external influence or force majeure.
- If the device is sold outside Europe, the manufacturer assumes no liability whatsoever. The device is designed, built and documented exclusively for the European Economic Area.
- In the event of resale of the device outside Europe, the seller has the full rights of ownership.
- The obligation to fulfil all legal requirements of the respective economic area/country.

The far infrared heater is to be operated exclusively in residential areas!

3.2 Applicable guidelines

>> See EC Declaration of Conformity in Chapter 9

3.3 Sales within non-European economic areas

The manufacturer accepts no liability if the far-infrared heating system is sold outside Europe. The machine has been designed, built and documented exclusively for the European Economic Area.

If the far-infrared heating system is resold outside Europe, then the seller is responsible for fulfilling all legal requirements of the respective economic area/country.

Safety

4

Intended use

4.1

The far infrared heaters are used to heat living spaces. The device heats objects and bodies in the wavelength range of 6 to 15 μm , which in turn give off the heat to the air in the room. The device can be mounted on the ceiling or wall in living rooms. Furthermore, the device may be operated on special feet that are only permitted for the device.

The device is built according to the state of the art and the recognized safety rules. However, inappropriate or improper use of the device may result in danger to life and health of the user or third parties or damage to the device and other material assets.

The area of application of the device is the residential area. It is intended for connection to a public power supply network. The manufacturer is not liable for non-observance and for damages resulting from this. The risk is borne by the operator.

If malfunctions occur during operation:

- Disconnect the unit from the power supply.
- Inform the manufacturer of the device.

Reasonably foreseeable misuse

Any other use than that described in these operating manual is considered as a foreseeable misuse.

These include:

- Operation without safety guards.
- Mechanical or electrical bridging,
- The use of parts other than the original parts.
- Modifications, changes and manipulations.
- Failure to follow the instructions.

4.2 Technical data

The following technical information refers to the entire information heating systems of the Könighaus Heating System. Specific information about your equipment can be found on the identification plate on the back of your heating panel.

Type	Tension (V)	Power (W)	Frequency (Hz)	Size (mm)	Weight (kg)	IP-protection class
P-130	220 - 240	130	50-60	505x385x20	1,9	44
P-300	220 - 240	300	50-60	605x505x20	2,7	44
P-450	220 - 240	450	50-60	905x505x20	3,8	44
P-600	220 - 240	600	50-60	1005x605x20	5	44
P-800	220 - 240	800	50-60	1005x605x20	5	44
P-1000	220 - 240	1000	50-60	1205x605x20	5	44
P-1200	220 - 240	1200	50-60	1205x605x20	5	44
M-300	220 - 240	300	50-60	595x505x20	2,48	44
M-350	220 - 240	360	50-60	595x595x20	2,9	44
M-450	220 - 240	450	50-60	905x505x20	3,58	44
M-600	220 - 240	600	50-60	1005x595x20	4,42	44
M-800	220 - 240	780	50-60	1005x595x20	4,42	44
M-1000	220 - 240	1000	50-60	1005x595x20	4,42	44
M-1200	220 - 240	1200	50-60	1195x1005x20	9,98	44
E-300	220 - 240	300	50-60	600x500x20	2	44
E-350	220 - 240	350	50-60	595x595x20	2	44
E-450	220 - 240	450	50-60	900x500x20	3	44
E-600	220 - 240	600	50-60	1013x595x20	3	44
E-720	220 - 240	720	50-60	595x1195x20	4	44
E-800	220 - 240	800	50-60	1000x780x20	4	44
E-1200	220 - 240	1200	50-60	1200x1000x20	7	44
GSP-300	220 - 240	300	50-60	700x600x30	7,76	44
GSP-450	220 - 240	450	50-60	1000x600x30	10,16	44
GSP-600	220 - 240	600	50-60	1000x600x30	11,56	44
GSP-800	220 - 240	800	50-60	1005x605x35	11,56	44
GSP-1000	220 - 240	1000	50-60	1005x605x35	11,56	44
G-300	220 - 240	300	50-60	700x600x30	7,76	44
G-450	220 - 240	450	50-60	1000x600x30	10,16	44
G-600	220 - 240	600	50-60	1000x600x30	9	44
B-300	220 - 240	300	50-60	650x550x300	3	44
DL-1000	220 - 240	600	50-60	1065x605x20	4,5	44
DL-1200	220 - 240	300	50-60	1065x605x20	4,5	44

Notes on energy consumption

4.2.1

The Ecodesign Directive (2009/25/EC) of the European Parliament regulates the requirements of energy-related products (ErP). Since 1.1.2018, infrared heaters must now also be labelled in accordance with Regulation 2015/1188/EU. In the following, the required data from the Regulation are presented:

The following products were selected as references:

- M-350, P-600, E-1200,
- G-300 und G-450
- GSP-300 und GSP-450.

Model identifier(s): M-350, G-300, SP-300					
Specifications	Symbol	Value	Unit	Specifications	Unit
Heat supply					
Only for single room electric storage heaters: Type of heat supply control					
Normal heat supply	P _{nom}	0,3	kW	Manuelle Regelung der Wärmzufuhr mit integriertem Thermostat	No
Medium heat supply (standard value)	P _{min}	0,0	kW	Manuelle Regelung der Wärmzufuhr mit Rückmeldung	No
Maximum continuous heat supply	P _{max,c}	0,3	kW	Electronic control of the heat supply with feedback of the room and / or outside temperature	No
Auxiliary power consumption				Heat supply with fan support	No
At normal heat supply	e _{lmax}	0,300	kW	Type of heat output/room temperature control	
At minimum heat supply	e _{lmin}	0,000	kW	Single-stage heat supply, no room temperature control.	No
In standby mode	e _{lsb}	0,000	kW	Two or more manually adjustable stages with no room temperature control.	No
				Room temperature control with mechanical thermostat	No
				With electronic room temperature control.	No
				Electrical room temperature control and time of day control.	No
				Electrical room temperature control and weekday control	Yes
Other control options					
				Room temperature control with presence detection	No
				Room temperature control with open window detection	Yes
				With remote control options	No
				With adaptive control	No
				With operating time limitation	No
				With black ball sensor	No

The data on the right side of the table are the same for all devices, and are therefore listed here once.

Model identifier(s): P-600			
Specifications	Symbol	Wert	Einheit
Heat supply			
Normal heat supply	P _{nom}	0,5	kW
Minimum heat supply (Standard value)	P _{min}	0,0	kW
Maximum continuous heat supply	P _{max,c}	0,5	kW
Auxiliary power consumption			
At normal heat supply	e _{lmax}	0,500	kW
At minimum heat supply	e _{lmin}	0,000	kW
In standby mode	e _{lsb}	0,000	kW
Model identifier(s): E-1200			
Specifications	Symbol	Wert	Einheit
Heat supply			
Normal heat supply	P _{nom}	1,1	kW
Minimum heat supply (Standard value)	P _{min}	0,0	kW
Maximum continuous heat supply	P _{max,c}	1,1	kW
Auxiliary power consumption			
At normal heat supply	e _{lmax}	1,100	kW
At minimum heat supply	e _{lmin}	0,000	kW
In standby mode	e _{lsb}	0,000	kW
Modellkennung(en): G-450, SP-450			
Specifications	Symbol	Wert	Einheit
Heat supply			
Normal heat supply	P _{nom}	0,4	kW
Minimum heat supply (Standard value)	P _{min}	0,0	kW
Maximum continuous heat supply	P _{max,c}	0,4	kW
Auxiliary power consumption			
At normal heat supply	e _{lmax}	0,400	kW
At minimum heat supply	e _{lmin}	0,000	kW
In standby mode	e _{lsb}	0,000	kW
B-300	220 - 240	300	50-60
DL-1000	220 - 240	600	50-60
DL-1200	220 - 240	300	50-60

Nameplate

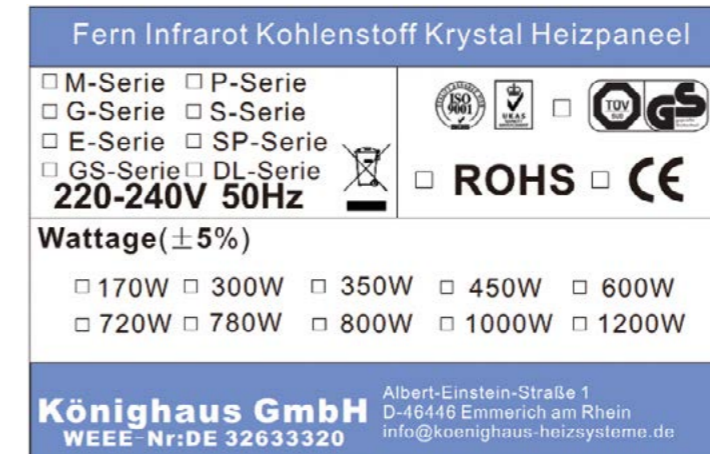

4.3

Labelling on the machine

Safety-related information in the form of pictograms and / or labels is attached to the device. They point out risks that:

- occur frequently and/or
- have serious consequences

The following labels are attached to the device:

Significance	Labelling
<p>Warning against hot surface! The device becomes very hot during operation (up to 125 °C depending on the model). Touching it can cause severe burns</p>	
<p>WARNING! To avoid overheating of the heater, the heater must not be covered.</p>	

4.3.1

4.4 Safety instructions



WARNING!

This device is not equipped with a system for controlling the room temperature. The heater must not be used in small rooms inhabited by persons who cannot leave the room on their own, unless the following conditions are met because constant monitoring is guaranteed.

- All Königshaus far infrared heaters are exclusively suitable for use as heating devices. Any improper use can lead to a considerable danger for humans, animals and the environment.
- For operation in commercial areas, the devices must only be installed and tested by qualified personnel (in compliance with national regulations).
- Children under three years of age must be kept away unless they are constantly monitored.
- Children 3 years and younger than 8 years may only switch the device on and off if they have been supervised or instructed on the safe use of the device and have understood the resulting dangers, provided that the device is placed or installed in its normal operating position. Children aged 3 years and younger than 8 years must not connect the plug to the socket, regulate the device, clean the device and/or carry out maintenance on the device by the user.
- **Caution** - Some parts of the product can become very hot and cause burns. Special care must be taken when children and people in need of protection are present.
- The heater must be installed so that switches and other controls cannot be touched by a person in the bathroom or shower.
- Under no circumstances whatsoever must the device be covered or sheltered. Direct contact may result in accumulation of heat, which could create hazard or occurrence of fire. The minimal distance of 50 cm must not be disrupted.
- Spacers must obligatorily be used at the installation.
- If the power cord of this device is damaged, it must be replaced by the manufacturer or his customer service or a similarly qualified person to avoid hazards.

- Persons with reduced physical, sensory or mental abilities or lack of experience and knowledge may only use the device under supervision or if instructed with regard to the dangers.
- Be careful not to expose your eyes intensively and for several hours to the far infrared rays, as this can cause damage to the eye.
- Far-infrared heaters are not suitable for use in the rain, under water, in very wet conditions, or for any other use other than that intended.
- Before mounting, please read the mounting instructions in chapter 5 Mounting.
- Only use in wet rooms after installation by a specialist.
- Do not use this heater near a bathtub, shower or swimming pool.
- The device may only be put into operation after appropriate and proper installation.
- If the device is damaged, it must be disconnected from the power supply and repaired by a specialist. Never repair it yourself!
- The heater must not be used if the compartments are damaged.
- The device must not be used for continuous time or permanently without a thermostat.
- If an automatically regulating thermostat is not used, the device can work for more continuous time only under supervision. Never leave the device for continuous time without supervision.
- The P series (600 W, 800 W, 1000 W and 1200 W) must be mounted so that the mains cable of the heater points downwards. The cable must be routed downwards and not upwards, behind or in front of the panel.
 - The safety notice „Don't cover“ must be properly read.

Energie

Electrical energy

The device is operated with a supply voltage of 220 - 240 V.

- If the plug or the power cable is damaged, the heating panel must not be used. This must be checked before each use.
- Never pull or tear the power cord.
- Do not pinch the power supply cable or run it over sharp/abrasive edges.
- Never open or repair the device yourself. This will render all warranty and liability claims invalid.
- Repairs must be carried out by a specialist.

Overheating

The far infrared heaters are equipped with overheating protection. If the overheating protection switches off, the plug must be removed. After a waiting time of approx. 10 to 15 minutes, the device will be ready for operation again.

- The only exceptions are the P and M series, as this is intended for installation in the power circuit.

Disposal



For the sake of our environment

The device contains components or substances which, in the event of improper disposal endanger the environment.

To avoid environmental damage, proceed as follows. Materials and components:

- Cardboard packaging material can be disposed of in the waste paper collection or the local disposal system.
- Dispose of plastic films and packaging properly. Keep out of the reach of children.
- Do not throw parts in the dustbin: The device must not be disposed of with household waste. Only to collection points for electrical and electronic equipment. The symbol of the crossed-out dustbin indicates this.
- By recycling, material recovery or other forms of recovery of old equipment, you are making an important contribution to protecting our environment. Please ask your local authority and the responsible disposal point for more information.

Mounting

5

You can see Video Tutorial here:

www.koenighaus-heizungsmotive.de/video-instructions.html



WARNING!

Please read all instructions before operating the device to prevent the risk of fire, electric shock or injury. Our far-infrared heaters may only be used with the original suspension provided and can be mounted. Warranty and liability for consequential damages are excluded for far-infrared heating systems used without original suspension.

General notes on mounting

5.1

- Various mounting types are available for the various models. Our far infrared heaters have certain suspension devices. These must be used for mounting.
- Our series M is designated for direct installation to the power supply network. The installation must obligatorily be carried out by a specialist. The infrared panel for heating with remote control is designated for fixed mounting on the ceiling and the wall.
- Remove the blue transportation protective film (series E, M, with glass and a mirror).
- Make sure that the power plug is not plugged in or that the device is already connected to the power circuit. The device may only be installed if it is not switched on.
- Under no circumstances should you drill holes in the far infrared heater. If this happens accidentally, do not operate the device under any circumstances and contact your dealer.
- For the Konighaus E and P-Series, use the enclosed mounting template and follow the mounting instructions to ensure easy and trouble-free installation.
- If the appliance is used in children's rooms or in rooms accessible to children, please ensure that the far infrared heater is suspended 1.20 metres above the floor.

- Distance to the rear side: Our infrared heating panels with remote control give off convection heat to the rear side (but not infrared radiation). Nevertheless, with a view to the ventilation make sure that the rear side of series Königshaus M (with fixing supports) is not at a distance smaller than 25 mm from the wall. This distance is guaranteed only when the attached fixing material for wall mounting is used. Distance of 10 mm should be observed for series P.
- Mounting on ceiling should be carried out by a specialist/electrician. The panel does not have a plug (it is connected directly to the power supply network) and must be used with a temperature regulating thermostat. At mounting on ceiling it must be obligatorily guaranteed that the distance from the aluminium cleats adds up to about 25 mm to guarantee the discharge of the hot air behind the panel and prevent accumulation of heat. Screws with size of over 25 mm must be used for the purpose.
- Distance to the front: Our far-infrared heaters emit far-infrared radiation only at the front. Ensure that the minimum distance of approx. 50 cm to the front, 20 cm to the side and up and down is 20 cm.
- When mounting in public areas, VDE 0108 must be observed.
- Direct splashing of water must be avoided. In case of mounting or use in wet rooms, the installation must always be carried out by a specialist company and in accordance with VDE 0100 parts 701, 702 and 703.
- When installing in wet rooms, care must be taken that the device cannot come into contact with water (shower and bathtub). Do not use wet fingers.
- Do not mount the heating device directly below or in front of a plug socket.
- The mains plug must be accessible after installation and must be able to be pulled out immediately if necessary.
- If the remote infrared heater is to be connected to a fixed installed electrical installation, a disconnecting device of the overvoltage category III must be provided for full disconnection. This connection work may only be carried out by a qualified specialist.

Installation of the Königshaus E-Series

5.1.1

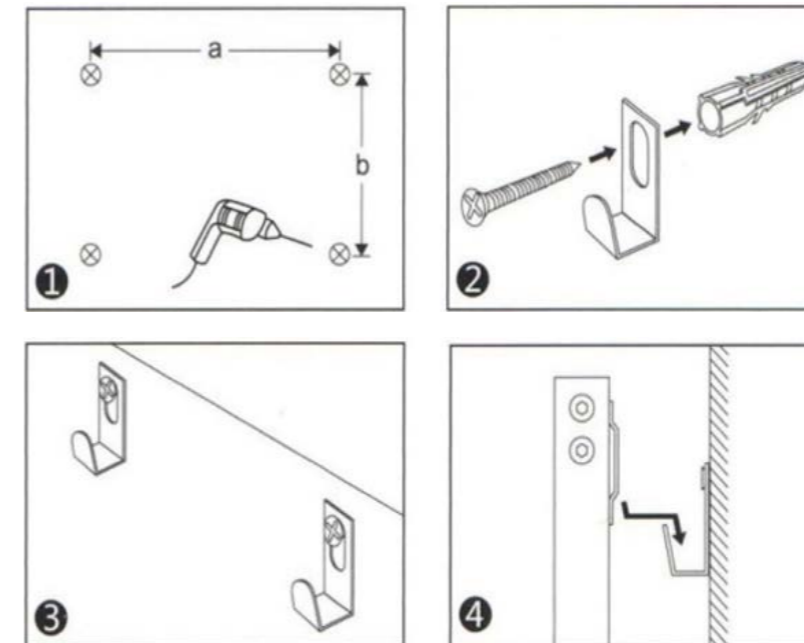

1. Drill the four holes into the wall according to the holding devices on the back and then insert the enclosed dowels into the holes so that they are congruent with the wall.
2. Then fasten the holders with a washer and screw (Series: Holder Washer Screw)
3. Align the brackets so that they are horizontal on the wall.
4. Place the wall-mounted panel in the holder. Make sure that the panel is firmly seated.

Indication: The installation is also valid for the **old series P**.



WARNING/NOTICE!

If the device is not installed properly, there are considerable dangers, such as dangers due to electric shock or fire. For this reason, operation of devices without a power plug must only be carried out by qualified specialists.

Make sure that the plug never leads upwards but always aside or downwards!

5.1.2 Installation of Königshaus P-, DL-Series, GSP 800 and GSP-1000

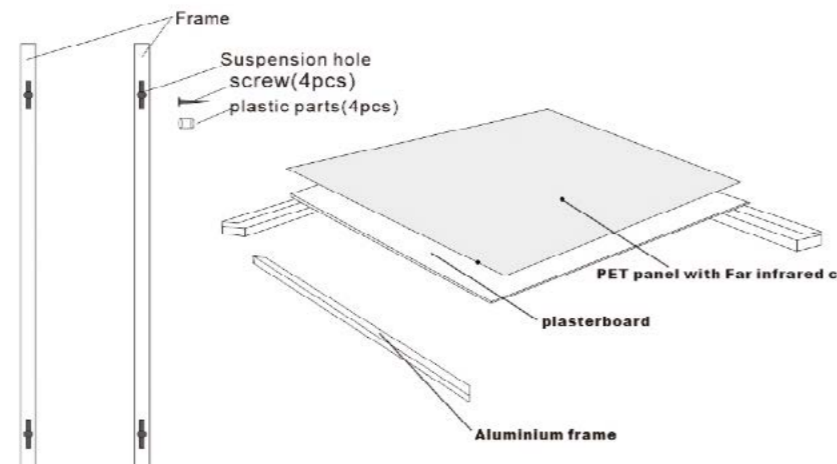

WARNING/NOTICE!

The P series must be mounted so that the mains cable of the heater points downwards. The cable must be routed downwards and not upwards, behind or in front of the panel.

Waagerechte Aufhängung:

1. Take the gauge board included in the delivery and attach it to the desired place on the wall with the help of adhesive tape. Outline the apertures for boring and bore holes on the four places outlined for the dowels provided.
2. Take the four plastic bolt pins (C) included in the delivery and place them on the four screws (B) included in the delivery. They provide the safe distance between the heating panel and the wall to avoid heat retention. There must be a little distance left between the head of the screw and the plastic bolt pin so that the screw could be fixed into the panel. The plastic bolt pins are respectively left in front of the suspension aperture (A) of the heating panel and provide the safe distance.
3. Bolt up the four screws (B) into the dowels/into the wall.
4. Take the heating panel and align it to the four screws (B). Carefully place the heating panel into the four apertures (A) of the frame. After placing the heating panel into the apertures (A), carefully align it to the right or to the left so that the heads of the screws should be exactly behind the slots of the aperture.
5. Carefully check whether each screw lies in each aperture and you will be ready!

Vertical suspension:

1. Take the gauge board included in the delivery and attach it to the desired place on the wall with the help of adhesive tape. Outline the apertures for boring and bore holes on the four places outlined for the dowels provided.
2. Take the four plastic bolt pins (C) included in the delivery and place them on the four screws (B) included in the delivery. They provide the safe distance between the heating panel and the wall to avoid heat retention. There must be a little distance left between the head of the screw and the plastic bolt pin so that the screw could be fixed into the panel. The plastic bolt pins are respectively left in front of the suspension aperture (A) of the heating panel and provide the safe distance.
3. Take the heating panel and align it to the four screws (B). Carefully place the heating panel into the four apertures (A) of the frame. After placing the heating panel into the apertures (A), carefully slide it into the slots so that the heads of the screws should be exactly behind the slots of the aperture.
4. Carefully check whether each screw lies in each aperture and you will be ready!

Installation of Königshaus M-, G-, GS- and SP Series

The mounting is necessary for the following devices:

- >> M-300, -360, -450, -600, -800, -1000, -1200
- >> GS-300, -450, -600
- >> SP-300, -450, -600

5.1.3

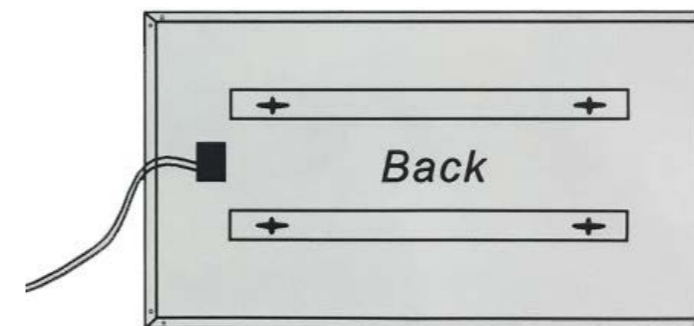

- If the infrared heating with remote control is connected to a fixed electrical installation, a magnetic separator of category of overvoltage III must be anticipated for full separation. These connection-related works may be executed solely by a qualified specialist

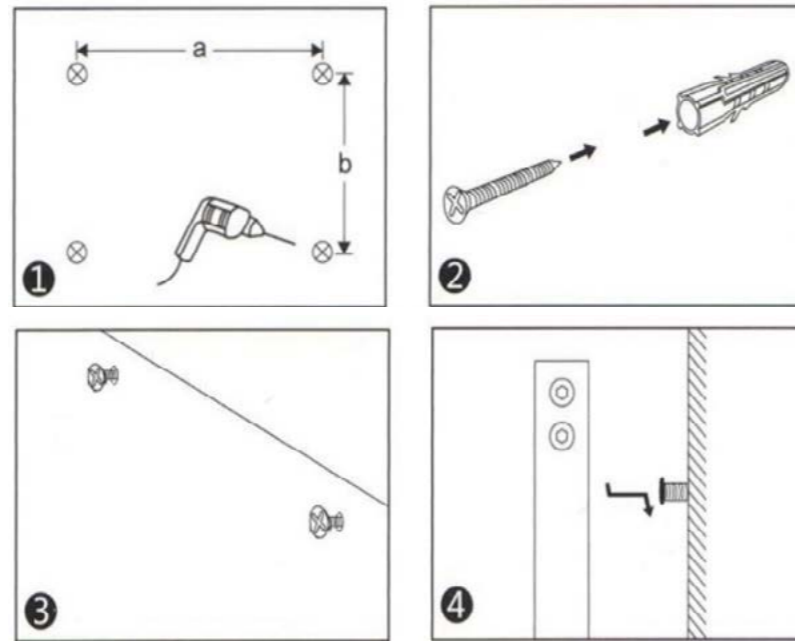

1. Bore four holes into the wall, corresponding to the fixing devices located from the rear side and after that insert the dowels included in the equipment into the holes, so that the same should be aligned with the surface of the wall.
2. After that the screws are bolted up into the holes so that they should slightly protrude out of the wall.
3. Underslung the fixing devices of the heating panel onto the screws.

5.2 Positioning

Make sure that the far infrared heater is not obstructed by cabinets, sofa or other objects and can radiate freely inside the room. The most efficient heating output is obtained with horizontal wall mounting. Further to that the heaters must not be mounted against glass. If the far infrared heater is prevented from radiating effectively into the room, a shadow effect is spoken about. To prevent this, contact your dealer to achieve optimum positioning.

Mounting and stand

5.2.1



Place the freely standing supporting feet on the floor. Insert the heaters into the groove anticipated for the purpose. After that tighten the heater with the screws anticipated for the purpose. These supporting feet are appropriate only for the infrared heating panels Königshaus of series P-E-DL.

6 Commissioning

Before commissioning, read Chapter 5 „Mounting“.

- Now connect the far infrared heater to a properly installed socket (observe the safety instructions described above). With the plugless far infrared heating systems, a prior check for damage by a specialist company is required.
- Now you can switch on the heating using the on/off switch
 - The on/off switch is located on devices of series E and Hybrid.
- The system takes about 5-10 minutes. If the room climate does not heat up immediately, please leave the far infrared heater in the room for a slightly longer time so that the cold objects (furniture, floors, ceilings, etc.) heat up.
- If you do not use the heater for a long period of time, disconnect the plug from the socket.

6.1 Notice on handling

- Do not place any clothing or similar objects on the device (fire hazard/congestion heat). The sign on the front must not be removed.
- When heating or cooling the device, the expansion of the material can cause minimal noise. This is normal and does not constitute a reason for complaint.
- The device becomes very hot during operation. Touching it can cause serious burns.
- The following far infrared heaters are equipped with overheat protection fuses:
 - P-Series, M-Series, E-Series, DL-Series, G-Series, GS-Series, LED-Series
- If the heater is not used for a longer period of time, disconnect the power plug from the power supply. To do this, please unplug the power plug from the socket.
- Please make sure that the surface of the far infrared heater is always clean when it is put into operation.
- Do not use the device for a long time period without supervision. The use of an automatically regulating the heating thermostat is recommended for permanent work.

7 Cleaning and maintenance

Cleaning

Our infrared heaters do not require regular maintenance. If you notice any irregularities, please disconnect the power plug and immediately contact your specialist dealer from whom you purchased the infrared heater.

To clean the unit, proceed as follows:

- Pull out the power plug.
- The device must have cooled down before cleaning (approx. 10 to 15 minutes after operation)
- Clean only with a dust cloth or damp cloth. Never immerse in water or wash off with water. Before restarting, make sure that wet areas are completely dry.
- Do not use abrasive agents or other aggressive agents or rough cloths.
- Ceiling heaters can be cleaned regularly with a vacuum cleaner.

Reparatur

- If you notice any irregularities or damage to the device, contact the dealer from whom you purchased the device.
- In any case, the power plug must be disconnected immediately in the event of a fault in the far infrared heating system. The device may only be put back into operation after the fault has been rectified by a specialist.
- Furthermore, we ask you to read through the more detailed warranty and handling information.
- Labels, warnings, serial numbers or nameplates must never be removed from the far infrared heater. The data on the nameplate is important for the warranty.

8 Troubleshooting

If the device is not heating, please check the following:

- Is the infrared heater connected to the power grid?
- Is the power switched off by an external switch?
- Is the fuse bad?
- Has the thermostat been set correctly? The desired temperature must be higher than the actual temperature.

Not getting the desired radiation heat:

- The distance between the device and the area to be heated must not exceed 2.5m.
- Is the performance of the model insufficient? (Ask your local dealer)
- Is there draught in the room?
- Are there any objects in front of the infrared heater that can cast a „shadow“? (See 5.2 Positioning)

9 Konformitätserklärung (DE)

Ferninfrarot-Carbon-
Kristall-Heizplatte

EG - Konformitätserklärung nach der Niederspannungsrichtlinie 2014/35/EU



Hiermit erklären wir, dass die nachfolgend bezeichnete Ferninfrarot-Carbon-Kristall-Heizplatte aufgrund ihrer Konzipierung und Bauform sowie in der von uns in Verkehr gebrachten Ausführung den einschlägigen grundlegenden Sicherheits- und Gesundheitsanforderungen der EG-Richtlinien entspricht.

Bezeichnung:	Königshaus
Modelle:	P-130, P-300, P-450, P-600, P-800, P-1000, P-1200 M-300, M-360, M-450, M-600, M-720, M-800, M-1000, M-1200 G-300, G-450, G-600, GSP-300, GSP-450, GSP-600 E-300, E-350, E-450, E-600, E-700, E-800, E-1200 Bogen, DL-Serie
Baujahr:	2015

entspricht folgenden EG - Richtlinien:	Niederspannungsrichtlinie 2014/35/EU EMV-Richtlinie 2014/30/EU RoHS - Richtlinie 2011/65/ EU ErP Richtlinie 2015/1188/EU Ökodesign-Richtlinie 2009/125/EG
--	--

Angewandte harmonisierte Normen, insbesondere:	DIN EN 60335-1:2012/A2:2019	Sicherheit elektrischer Geräte für den Hausgebrauch und ähnliche Zwecke – Teil 1: Allgemeine Anforderungen
	DIN EN 60335-2-30:2009/A12:2020	Sicherheit elektrischer Geräte für den Hausgebrauch und ähnliche Zwecke - Teil 2-30: Besondere Anforderungen für Raumheizgeräte
	DIN EN 62233:2008	Verfahren zur Messung der elektromagnetischen Felder von Haushaltsgeräten und ähnlichen Elektrogeräten im Hinblick auf die Sicherheit von Personen in elektromagnetischen Feldern
	DIN EN 55014-1:2021	Elektromagnetische Verträglichkeit - Anforderungen an Haushaltgeräte, Elektrowerkzeuge und ähnliche Elektrogeräte - Teil 1: Störaussendung
	DIN EN 55014-2:2021	Elektromagnetische Verträglichkeit - Anforderungen an Haushaltgeräte, Elektrowerkzeuge und ähnliche Elektrogeräte - Teil 2: Störaussendung
	DIN EN IEC 61000-3-2:2019/A1:2021	Elektromagnetische Verträglichkeit (EMV) - Teil 3-2: Grenzwerte - Grenzwerte für Oberschwingungsströme (Geräte-Eingangstrom ≤ 16 A je Leiter)
	DIN EN 61000-3-3:2013/A2:2021	Elektromagnetische Verträglichkeit (EMV) - Teil 3-3: Grenzwerte - Begrenzung von Spannungsänderungen, Spannungsschwankungen und Flicker in öffentlichen Niederspannungs-Versorgungsnetzen für Geräte mit einem Bemessungsstrom ≤ 16 A je Leiter, die keiner Sonderanschlussbedingung unterliegen

Bei einer Änderung dieser Ferninfrarot-Carbon-Kristall-Heizplatte verliert diese Erklärung ihre Gültigkeit. Die speziellen technischen Unterlagen für diese Ferninfrarot-Carbon-Kristall-Heizplatte nach Anhang VII Teil A sind erstellt worden.

Hersteller/
Dokumentationsbevollmächtigter: Königshaus GmbH
Albert-Einstein-Straße 1
D-46446 Emmerich am Rhein

Emmerich, 28.10.2022
Ort, den Datum

Robin Königshaus
- Geschäftsführer -

Declaration of conformity

9

Far Infrared Carbon-Crystal
heating device

EC-Declaration of Conformity
according to the Low Voltage
Directive 2014/35/EU



We herewith declare that due to its design and construction as well as the design we have placed on the market, the following far infrared carbon-crystal heating devices comply with relevant basic safety and health requirements of the EC-directives.

Label:	Königshaus
Model:	P-130, P-300, P-450, P-600, P-800, P-1000, P-1200 M-300, M360, M-450, M-600, M-720, M-800, M-1000, M-1200 G-300, G-450, G-600, GSP-300, GSP-450, GSP-600 E-300, E-350, E-450, E-600, E-700, E-800, E-1200 Ark, DL-series
Year:	2015

Complies with the following EU-Directive:

Low Voltage Directive 2014/35/EU
RoHS-Directive 2011/65/EU
ErP-Directive 2015/1188/EU
Ecodesign Directive (2009/125/EC)

Harmonized standards applied, in particular:

DIN EN 60335-1:2012/A2:2019	Household and similar electrical appliances - Safety - Part 1: General requirements
DIN EN 60335-2-30:2009/A12:2020	Household and similar electrical appliances - Safety - Part 2-30: Particular requirements for room heaters
DIN EN 62233:2008	Method for measuring the electromagnetic fields of household appliances and similar electrical equipment with regard to the safety of persons in electromagnetic fields
DIN EN 55014-1:2021	Electromagnetic compatibility - Requirements for household appliances, electric tools and similar apparatus - Part 1: Emission
DIN EN 55014-2:2021	Electromagnetic compatibility - Requirements for household appliances, electric tools and similar apparatus - Part 2: Emission
DIN EN IEC 61000-3-2:2019/A1:2021	Electromagnetic compatibility (EMC) - Part 3-2: Limits - Limits for harmonic current (equipment input current ≤ 16 A per phase)
DIN EN 61000-3-3:2013/A2:2021	Electromagnetic compatibility (EMC) - Part 3-3: Limits - Limitation of voltage changes, voltage fluctuations and flicker in public low-voltage distribution systems for equipment with a rated current ≤ 16 A per phase and not subject to special connection conditions

In the event of a modification of this far-infrared carbon crystal heating panel, this declaration shall lose its validity. The specific technical documentation for this far-infrared carbon crystal hotplate according to Annex VII Part A has been prepared.

10 Guarantee provision statement

Dear customers,

We congratulate you for the purchase of a heater from Königshaus Company. In this manner, you acquired a product manufactured in conformity with the present level of the technologies. Our products are subject to strict control over the quality. If, contrary to expectations, this product is in a faulty condition, please, pay attention to our guarantee provision statement.

Königshaus offers gratuitous 5-year guarantee for all infrared heating panels purchased by users after 01.01.2017. This refers exclusively for all the heating devices with Koenighaus brand.

Guarantee of the manufacturer for heating systems of Königshaus Guarantee provision statement

Along with and further to the quality guarantee of the Seller, Company Königshaus GmbH, Albert-Einstein-Str. 1, D-46446 Emmerich am Rhein (here in after referred to as Königshaus) grants to the users a guarantee for the preservation of the quality under the following conditions and within the scope described herein below: In its capacity of manufacturer, Königshaus guarantees for a limited time period the flaw- less functioning of the properly used heating systems Königshaus. "User" within the meaning of this guarantee of a manufacturer shall be each natural person who is an owner of the product Königshaus and who did not acquire it to resell or install it with third persons within the framework of his business activity or exercised freelance job.

First end user shall be the user who first purchased the product from Königshaus, from a distributor or from another natural or legal person which sells or mounts the product Königshaus within the framework of his business activity or exercised freelance job.

Königshaus guarantees the flawless functioning of the distributed by the same products on the territory of the European Union (EU), Andorra, the Faroe Islands, Kosovo, Liechtenstein, Macedonia, Norway, San Marino, Switzerland, Serbia, Turkey, with appropriate use within the framework of the agreed guarantee period under the conditions indicated herein below. If a certain product of Königshaus shows a functioning irregularity within the framework of the guarantee period in conformity with these guarantee conditions, Königshaus in its judgment shall be obligated to carry out the gratuitous for the first end user repair of the product or gratuitous replacement with a corresponding or similar or equivalent product of Königshaus.

Guarantee period:

The guarantee period shall be 5 years and shall commence to elapse from the day of the purchase of the first end user. In events of claims, turn directly to the Seller presenting the product and a purchase document. After the second year, turn directly to the manufacturer to clarify how it should be proceeded.

Conditions of the guarantee of the manufacturer:

The guarantee provision statement assumes that the user accepts the same with regard to Königshaus in writing. This should be made: a) through registration within the framework of 24 months from the date of the purchase at e-mail: garantie@koenighaus-heizsysteme.de and b) through presentation of an original document for purchase of the products of Königshaus included in the guarantee, and c) through presentation of the product Königshaus, as well as evidence that the functional irregularity arose within the framework of the guarantee period. Similar evidence may be, in particular, the presentation of a sale document.

Scope of the guarantee:

This guarantee shall be valid for products of Königshaus, purchased by the first end users after 01.01.2013 (the date on the sale document shall be determinative). Königshaus guarantees to the users that the products Königshaus are without defects in the materials, without production and structural defects. The level of the technical and scientific progress as of the time of the manufacture is of decisive significance at that. As of this time the product should have already shown the fault which caused the damage. The guarantee comprises in particular the working function for heating, the operational reliability of the electronic components and cables, the absence of defects in the materials and their surfaces, in particular plastic, glass and metal.

The following shall be valid with regard to the guaranteed appropriate function for heating for the heating systems Königshaus:

In conformity with the state-of-the-art level of the technical and scientific progress, the heating power may slightly decrease in the course of the operational life. Königshaus guarantees the proper function for heating of heating systems Königshaus in compliance with the operational life of similar heating systems. In conformity with the state-of-the-art level of the technical and scientific progress, Königshaus guarantees that the fixedly mounted in the heating systems Königshaus heating pads preserve at least 70 % of their heating effect during the operational life of the relevant mounted heating system indicated on the product, This means that the decrease of the heating power of the heating systems Königshaus within the scope indicated hereinabove within the framework of the operational life does not constitute a defect in conformity with the state-of-the-art level of the technical and scientific progress.

Guarantee waiver:

These guarantee conditions shall be fulfilled provided that the products Königshaus are used as intended:

- No mounting of devices or restructurings shall be wifully undertaken we well as other modifications pertaing to the products Königshaus
- The maintenance of the products Königshaus shall be made in conformity with the Maintenance Instructions of Königshaus
- The mounting and the installation were carried out in compliance with the mounting instructions of Königshaus, with observation of the limit values for power supply voltage and environmental impact
- There are no chemical or physical impacts on the surface of the material of the products Königshaus, arisen as a result of inappropriate use (for instance, due to damages as a result of improper use of detergents or objects with sharp edges.) The damages occurred as a consequence of that are not covered by the guarantee,
- These products of Königshaus were not purchased as a revalued article or sample,
- These products of Königshaus were not purchased from the manufacturing plant (a certifying document).

This guarantee shall refer exclusively to products of Königshaus, purchased on the territory of the European Union (EU), Andorra, the Faroe Islands, Kosovo, Liechtenstein, Macedonia, Norway, San Marino, Switzerland, Serbia, Turkey and delivered by Königshaus to a local distributor. The products of Königshaus, which get within the scope of the guarantee in other manners, are expressly excluded from this guarantee.

Guarantee maintenance:

The guarantee maintenance consists exclusively of the fact that in event of occurred functional irregularity within the framework of the guarantee period, Königshaus Heizsysteme in its judgment shall be obligated to carry out the gratuitous for the first end user repair of the product or gratuitous replacement with a corresponding or similar or equivalent product of Königshaus. Königshaus shall reserve the right to adapt the services for the guarantee maintenance to the technical progress. The expenses arisen for the recipient of the guarantee, per diem, postal costs and others of the kind, shall not be subject to refunding. The costs for assem- bly, disassembly and transportation shall not be subject to refunding, either. The production losses, the profit lost and the subsequent losses arisen as a consequence of a defect in a product of Königshaus, shall not be covered by the guarantee. Claims for indemnity for subsequent losses or such ensuing from a guarantee of a manufacturer, however, shall be allowed for solely in conformity with the mandatory legal provisions. A claim related to a guarantee shall be accepted solely against presentation of the product as

well as of evidence that the functional irregularity arose within the framework of the guarantee period. Similar evidence may be, in particular, the presentation of a sale document. In this connection you are recommended to store the sale document in a secure place at least up to the expiration of the guarantee period.

Instructions on the guarantee obligations, Section 477 Civil Code:

Irrespective of this guarantee of a manufacturer and of the fact whether with regard to a guarantee event the prescribed guarantee is used or not, the legal rights of the user pertaining to the Seller shall remain unlimited. Due to that, in own judgment, further to or without lodging guarantee claims to the Seller, the legally regulated rights of the Buyer due to defects in the purchased goods may be claimed – in particular, elimination of defects, refusal, reduction of the purchase price or indemnity for damages caused (see Section 437 of the Civil Code and the relevant special limitation rules in paragraph 438 of the Civil Code). The guarantee shall be applied without affecting the mandatory legal provisions with regard to the responsibility as, for instance, in conformity with the Production Quality Responsibility Act, in the events of malice and gross negligence, at causing death, bodily injury or harm to the health on the part of Königshaus or their representatives.

Königshaus GmbH, Albert-Einstein-Str. 1, D-46446 Emmerich am Rhein